

This document must be retained for future reference.

It is the responsibility of the person installing the electrical equipment to ensure that the installation meets the requirements of the IET wiring regulations and is therefore 'fit for purpose'. Factors such as correct selection of components, cable sizing, protective devices and Earth bonding are all critical and should be checked prior to full testing and power-up. Any other regulations applicable to the equipment being installed such as the Machinery Directive and current health and safety legislation must also be adhered to.

All connections (including factory made) must be checked for the correct tightness prior to commissioning of the electrical installation. All connections should also be inspected periodically to ensure correct tightness.

**DO NOT USE POWER TOOLS ON THESE PRODUCTS**



### LBDC162P IP66 Enclosed Switch Disconnectors



#### Applications

- Photovoltaic - Isolators
- Inverter Applications
- DC Solar Pumps

#### Features

- Compact and reliable
- IP66
- Easy Installation
- Wiping contacts
- Excellent switching and high short circuit capacity

DC Isolators Rating Table				
Type	Configuration	IEC Rating 60947-3- DC21B & DC PV2		
		500V	700V	1000V
LBDC162P	 2 Poles in series	16	16	9

### Switching Configuration:

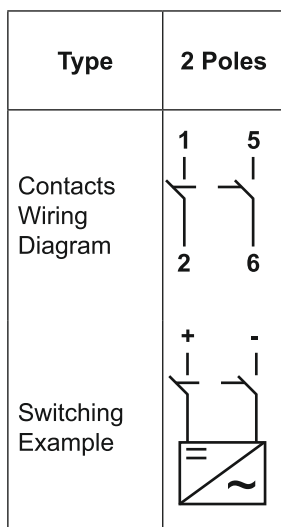

Terminal Cross Section		Measure	LBDC162P
Single / Multi Strand Wire	Min	mm <sup>2</sup>	2.5
	Max	mm <sup>2</sup>	10
Fine Strand Wire with Sleeve	Min	mm <sup>2</sup>	0.75
	Max	mm <sup>2</sup>	6
Recommended Tightening Torque for Terminals		Nm	1.7

## Dimension Details :

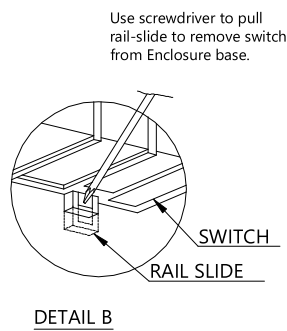
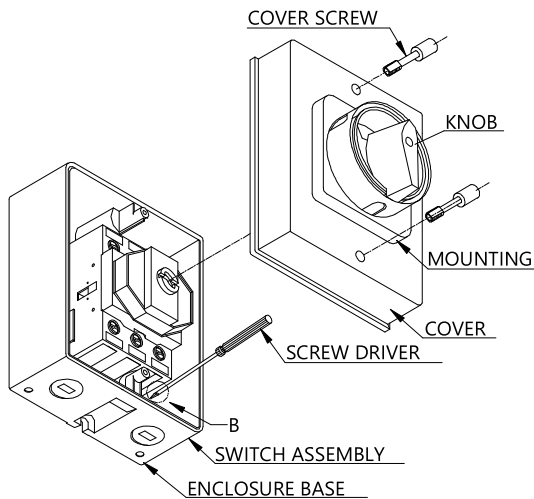
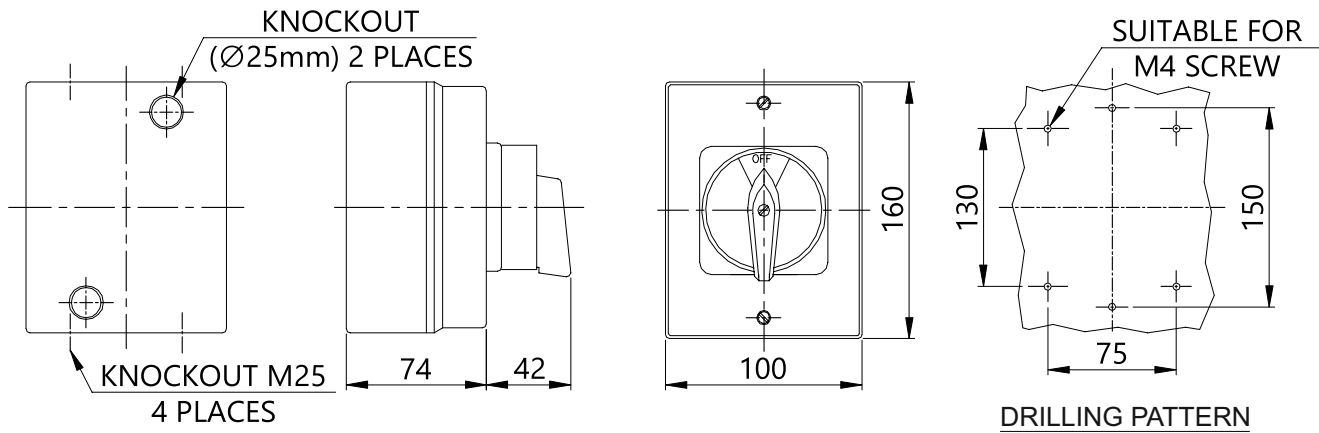

## Handle for testing:

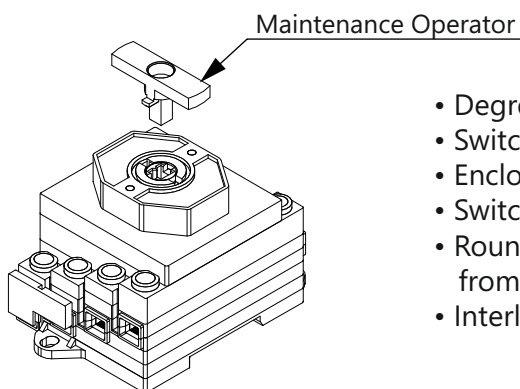

- Degree of Protection: IP66
- Switch rear mounted for easy connection
- Enclosure colour: Dark grey base and light grey cover.
- Switch mounted in Polycarbonate enclosure.
- Round padlocking device (Max.3 padlocks) to prevent the Switch from being made ON by unauthorised personnel
- Interlock Feature (Cover opens only in OFF position)